

WIHA Refrigerated Display Cases

With WIHA you have all advantages on your side



Short delivery times!



WIHA

Refrigerated Display Cases ECO

For environment and climate!

- Long-lasting product freshness
- Transparent appearance
- Energy-saving insulating glazing
- Maintenance-free LED lighting
- Front and side glass panels made from double safety glass

WIHA Refrigerated Display Cases

Huge selection for almost all scopes



FrontSeller XL

Bottle cooler with bottle slide

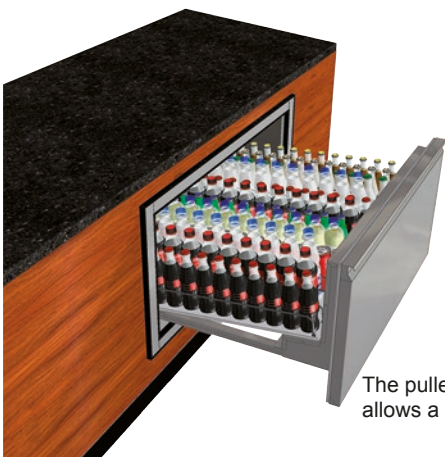

The pulled-out drawer on operator's side allows a quick and easy refill with bottles.



Fan-assisted (circulating air) bottle cooler FrontSeller XL

- Optimal presentation of the beverages on a bottle slide (first in – first-out)
- Outstanding capacity of approx. 150 bottles
- Individual adjustable divider bars (3,5 mm grid)
- Highly luminous lighting track
- Simple refill from operator's side
- Liftable evaporator for an easy and fast cleaning
- Highly effective refrigeration due to air curtain technology
- Comfortable digital temperature and defrosting controller



The 3.5mm grid of the merchandise display enables the adjustment of the divider bars to match the size of the bottles.

The WIHA Bäcker-Snack

The better air chiller unit for cakes, cream cakes and snacks

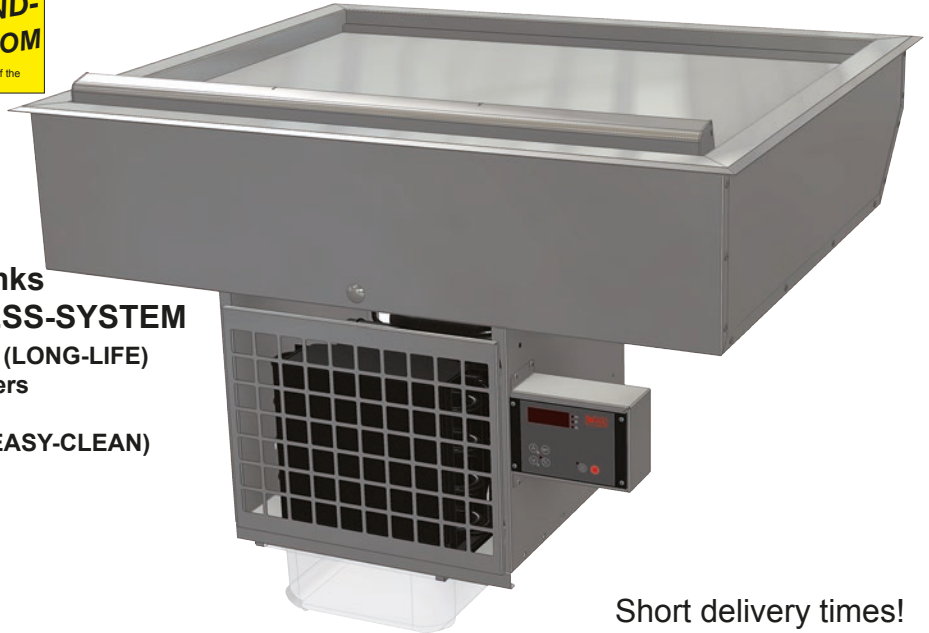

Short delivery times!

Food stays fresh for longer thanks to the patented WIHA FRESHNESS-SYSTEM

- Longer operating life of the cooling unit (LONG-LIFE)
- Hygienic base with round shaped corners (ROUND-BOTTOM)
- Easy cleaning of the air blow-off area (EASY-CLEAN)
- Extra-large evaporator
- 4°C cooling technology
- 2 air speeds
- Lifiable evaporator
- Service friendly
- Separate mounting frame
- Durable Papst ventilators
- Comfortable digital temperature and defrost controller

Bäcker-Snack® HOT-COLD

HOT or COLD – respond to your customers' demands!



HOT-COLD
30-75°C < 5°C

Preferred Application:
COLD: Cakes, tarts, sandwiches and snacks with a merchandise height of approx. 6 to 8 cm.
HOT: Pizza, croissants, pies, etc. (To improve the heat distribution, we recommend additional heat radiators.)

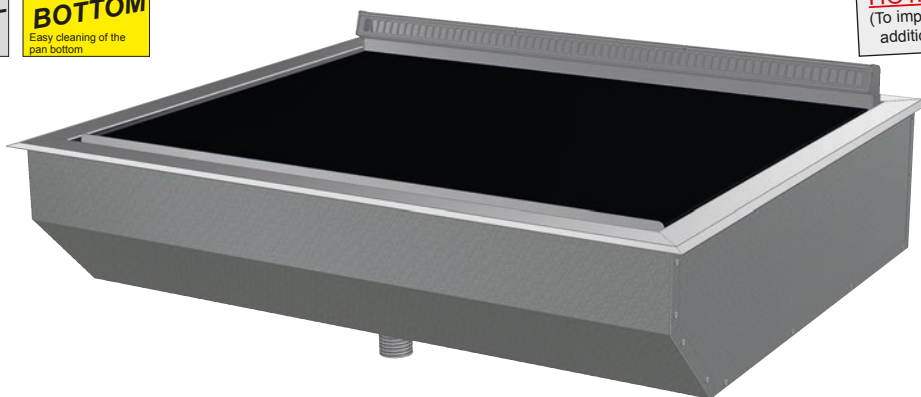

The patented **WIHA HOT-COLD-TECHNOLOGY!**

As seasons and daytimes are changing constantly, your customers' tastes vary accordingly. Maybe cold snacks throughout the day and a warm snack in the afternoon. Your counter should be as flexible as your customers are.

Wouldn't it be good to have a unit that offers both solutions?

The "Bäcker-Snack HOT-COLD" is the answer to this question. Its child's play to switch the operation mode from cold to hot and back!

New Tiered Refrigeration Modules SKE

Optimised for refrigeration of exposed food

- A deep cold reservoir results in excellent cooling
- A large evaporator and low air speed prevent excessive drying out
- Suitable for merchandise with a height up to 18 cm
- Optimised solutions for cakes, flans, meat, cheese and delicacies

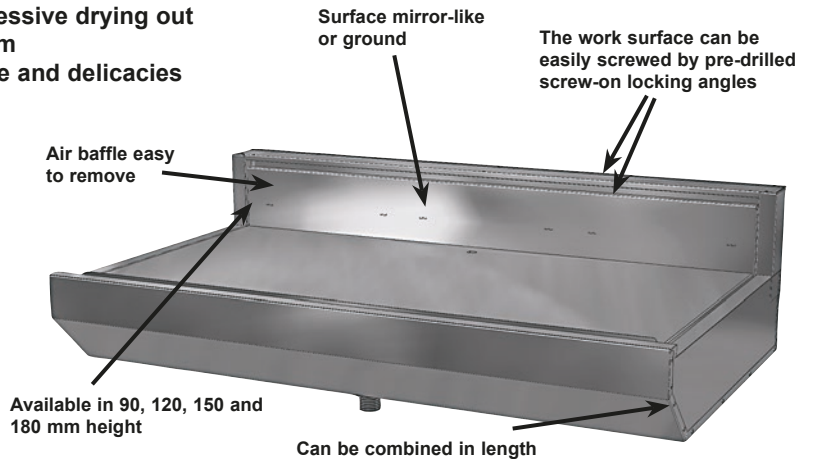
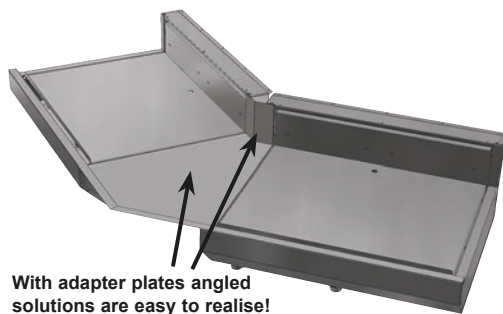

GUSTO for a better taste!

Air chiller unit to establish your individual food counter



- Perfect product presentation
- Long freshness due to high humidity
- Easy and safe cleaning (lift evaporator)
- Highly economical and energy efficient
- Optional available WIHA-FRESHNESS-SYSTEM
- Angled or arcuate shapes possible!
- With WIHA-LONG-LIFE for a longer operating life of the cooling unit

RONDO

The no-frost system tailored to your requirements

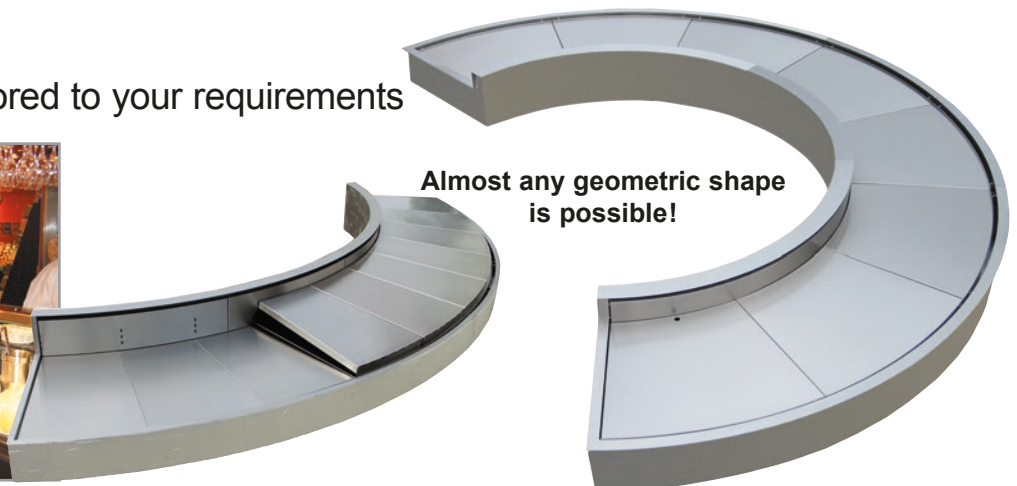

Under Counter Refrigerators KUB

Modern and attractive stainless steel design

- High-quality stainless steel front with integrated handle bars
- Double-walled body, seamless foamed (CFC-free)
- Interior and on the service side made entirely of stainless steel
- Air circulation ranges for even temperature distribution
- High-quality coated circulating air evaporator with stainless steel housing
- System-tested cooling units, extractable on rails for easy maintenance
- Refrigerated compartments equipped with magnetic door seals with hollow chambers
- Digital controller with automatic defrosting
- Controller with interface for recording the temperature and temperature monitoring (HACCP)
- ECO mode to reduce energy consumption
- HACCP button to query the highest temperature
- Glass doors with LED lighting available

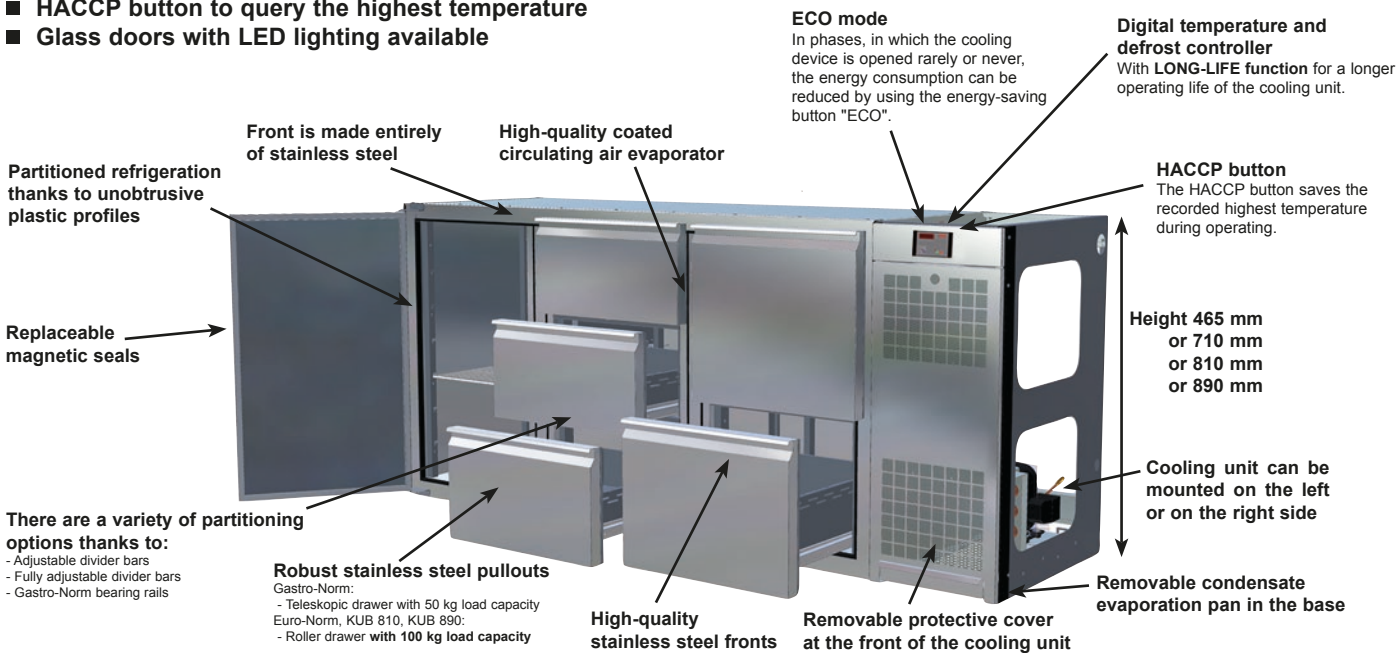

Wing door inserts are also available with glass window and LED lighting.



Please ask for our catalogue!



WIHA-THEKENTECHNIK
Hakemann GmbH & Co. KG
Barnstorfer Str. 31
D-49424 Goldenstedt
Tel.: +49 (0) 4444 9636-0
Fax: +49 (0) 4444 9636-19
wiha@hakemann.de
www.wiha-web.com



Short delivery times!